

K.S.RANGASAMY COLLEGE OF TECHNOLOGY
(An Autonomous Institution affiliated to Anna University, Chennai and approved by AICTE, New Delhi)
TIRUCHENGODE- 637215



M.B.A

REGULATIONS 2025

CHOICE BASED CREDIT SYSTEM
(Academic year 2025-2026 onwards)

CONTENT

| S.No. | Particulars | Page. No |
|--------------|----------------------------------------------------------|-----------------|
| 1. | Preliminary Definitions and Nomenclature | 4 |
| 2. | Admission Procedure | 4 |
| 3. | Programmes offered | 5 |
| 4. | Structure of the Programme | 5 |
| 5. | Medium of Instruction | 10 |
| 6. | Duration of the Programme | 10 |
| 7. | Course Registration | 11 |
| 8. | Requirements of Attendance and Progress | 12 |
| 9. | Readmission | 12 |
| 10. | Class Advisor | 13 |
| 11. | Class Committee | 13 |
| 12. | Course Committee for Common Courses | 15 |
| 13. | System of Examination | 15 |
| 14. | Procedure for Awarding Marks for Internal Assessment | 16 |
| 15. | Requirements for Appearing for End Semester Examinations | 22 |
| 16. | Passing Requirements | 22 |
| 17. | Award of Letter Grades | 24 |
| 18. | Eligibility for the Award of the Degree | 26 |
| 19. | Provision for Withdrawal from End-Semester Examination | 27 |
| 20. | Provision for Authorized Break of Study | 28 |
| 21. | Discipline | 29 |
| 22. | Revision of Regulations, Curriculum and Syllabi | 29 |
| 23. | Annexure – I Mapping of NPTEL Marks with Grades | 31 |
| 24. | Annexure – II – Internship Assessment Report | 33 |

(i)

K.S. RANGASAMY COLLEGE OF TECHNOLOGY, TIRUCHENGODE- 637 215

(An Autonomous Institution, Affiliated to Anna University, Chennai and approved by AICTE, New Delhi)

Vision

To produce the most competent Scientists, Engineers, Technologists, Entrepreneurs, Managers and Researchers through quality Education.

Mission

To achieve academic excellence in Science, Engineering, Technology, Management and Research through objective and innovative teaching methods; dedicated and duty conscious faculty; continual and consistent updation of facilities; welfare and quality improvement of the faculty and a system of continual process improvement.

M.B.A REGULATIONS 2025

These regulations are applicable to the candidates admitted to M.B.A Programme from the academic year 2025-2026 onwards.

The regulations for the M.B.A Degree program are prepared with the recommendation guidelines and directions from the National Knowledge Commission, University Grants Commission (UGC) and All India Council for Technical Education (AICTE) on:

- (a) Outcome Based Education Framework (OBE)
- (b) Evaluation Reforms in Higher Education Institutions in India
- (c) Examinations Reform Policy
- (d) National Education Policy

In addition to the above documents, the best practices of KSRCT such as promoting enhanced learning and research capabilities through (a) Critical Thinking (b) Problem Solving (c) Analytical Reasoning (d) Scientific Reasoning (e) Reflective Thinking (f) Design thinking etc., are integrated into the Curricula.

Degree of Master of Business Administration

I. PRELIMINARY DEFINITIONS AND NOMENCLATURE

In these Regulations, unless the context otherwise requires:

- i. **University** means the Affiliating University, i.e. Anna University, Chennai.
- ii. **College** means K.S.Rangasamy College of Technology, Tiruchengode, an Autonomous Institution affiliated to Anna University, Chennai and approved by AICTE, New Delhi.
- iii. **Programme** means Post graduate Degree Programme M.B.A Degree Programme.
- iv. **Course** means a theory / theory cum practical / practical subject that is offered in a semester.
- v. **Credit** means the weightage given to each course to describe the candidate's workload required per week and it is used to compute the Grade Point Average (GPA) and Cumulative Grade Point Average (CGPA) of the student.
- vi. **Grade** means the letter grade assigned to each course based on the marks range specified.
- vii. **Grade Point** means a numerical value (0 to 10) allocated based on the grade assigned to each course.
- viii. **Head of the Institution** means the Principal of the Institution.
- ix. **Controller of Examinations (CoE)** means the authority of the Institution who is responsible for all activities of the Semester Examinations of the Institution.
- x. **Department** means the team of faculty members who are responsible for a program of study.
- xi. **Head of Department / BoS Chairman** means the person who is heading a particular department.

2. ADMISSION PROCEDURE

- 2.1 The candidates for seeking admission to the M.B.A degree programme for first semester will be required to satisfy the conditions of admission there to prescribed by the Anna University, Department of Technical Education, Government of Tamil Nadu, AICTE/UGC and to have passed appropriate Under Graduate Degree Examination of Anna University or equivalent as specified under qualification for admission as per the (TANCA) criteria. This is applicable for students admitted through government and management quota. Tamil Nadu Common Admission with 65% admission of sanctioned intake through Government Quota and 35% admission of

sanctioned intake through management Quota and 10% admission of sanctioned intake through lateral entry. AICTE supports 5% of admission through Tuition Fee Waiver Scheme, 5% of admission through Non-Resident Indian(s)(NRI) category. Also, AICTE supports admission of over and above 15% of the approved intake for Foreign Nationals / Overseas Citizen of India (OCI) / Children of Indian Workers in Gulf Countries / UGC.

- 2.2** The University may decide to restrict admission in any particular year to students having the subset of qualifications prescribed at the time of admission.
- 2.3** Notwithstanding the qualifying examination the student might have passed, he/she shall have a minimum level of proficiency in the appropriate Programme / courses as prescribed by the University from time to time.
- 2.4** Eligibility conditions for admission such as the marks, class obtained, the number of attempts in the qualifying examination and physical fitness shall be as prescribed by the University from time to time.

3. PROGRAMMES OFFERED

The following M.B.A (2 Years) degree programmes are offered by the college, affiliated to Anna University, Chennai, and AICTE, New Delhi, as in Table 1.

Table 1: Programmes Offered

| Sl.No. | Programme Code | Name of the Programme |
|---------------|-----------------------|-------------------------------------------|
| 1. | MB | M.B.A - Master of Business Administration |

4. STRUCTURE OF THE PROGRAMME

4.1. Categorization of Courses

The M.B.A. Programme will have a curriculum and syllabi consisting of theory courses, elective courses, open elective courses, seminar, practical, Industry / Institution Internship, Industrial Training / Mini-Project, Social Immersion Project / Summer Internship / Project Work as prescribed by the respective Board of Studies from time to time.

The courses shall be categorized as follows:

- i. **Foundation Courses (FC)** may include the Mathematics or other basic courses.
- ii. **Professional Core Courses (PC)** include the core courses relevant to the chosen specialization / branch
- iii. **Professional Elective Courses (PE)** include the elective courses relevant to the chosen specialization / branch

- iv. **Non-Functional Elective Courses (NEC)** include elective courses outside of the area of specialization
- v. **Research Methodology and IPR Course (RM)** covers topics on the process of Research and Patenting
- vi. **Career Guidance Courses (CG)** include Project Work, and/ or Internship, Seminar, Professional Practices, Summer Project, Case Study and Industrial / Practical Training.

The electives from the curriculum are to be chosen with the approval of the Head of the Department.

4.2 Number of courses per semester

Each semester curriculum shall normally have a blend of lecture courses with Theory courses and Theory cum practical courses and Employability Enhancement Course(s) and Laboratory Courses. Each Course shall have credits assigned as per clause 4.3.

4.3 Credit Assignment

Each course is assigned certain number of credits based on the following:

Table 2: Credit Assignment

| Contact period per week | Credits (C) |
|---------------------------------------------------------------------------|-------------|
| 1 Lecture (L) Hour | 1 |
| 2 Tutorial (T) Hour | 1 |
| 1 Laboratory Period (also for CG courses like Seminar, Project Work, etc) | 0.5 |

4.4 Project Work

The Project work is an important component of post-graduate programmes. The Project Work has to be undertaken in the final semester.

- 4.4.1 The Project work for M.B.A shall be pursued for a period of 16 weeks during the final semester, with an additional of maximum 4 weeks for report writing, the total project duration not exceeding 20 weeks.
- 4.4.2 The Project work shall be carried out under the supervision of a “qualified teacher” in the Department concerned. In this context “qualified teacher” means a faculty member possessing (i) PG degree with a minimum of 3 years of teaching experience or (ii) Ph.D. degree.
- 4.4.3 A student may, however, undergo Industrial Project in industry / academic / research institutions in lieu of project work a maximum of 120 days during Semester IV. Students shall undergo the Industrial Project with the approval obtained from the Head of the Department and Head of the Institution preferably one month before the start of the industrial project. In such cases, the Project work shall be jointly supervised by a supervisor of

the department and an external guide (mentor) from the industry, who shall be part of the project evaluation committee along with the supervisor in the department of the student.

Both guides are expected to interact regularly monitoring the progress of the student. For the reviews the external guide should be present atleast in online mode to assess and award marks to the student. The internal guide should ensure in the beginning of the project, that the work to be carried out is upto the standard as well as not attracting any IPR issues with the external organization so that the thesis work could be published. The reviews may be conducted in online mode, if the student cannot travel to Institution to attend the reviews and this shall be approved by HoD and such reviews have to be recorded.

In the final Thesis report, the bonafide certificate shall be signed by both the guides mandatorily. However, if any difficulty is encountered in fulfilling this norm then the HoD can initiate remedial action and complete the evaluation requirement with justification and approval of the Head of the Institution.

The Bonafide certificate of the project report shall have the date of viva voce examination and the signatures of the internal and external guides.

- 4.4.4** All Students shall submit the final project work report on or before the last working day of the semester as per the academic calendar published by the college.
- 4.4.5** If a student fails to submit the project report on or before the specified deadline, he/she shall meet the HoD and give suitable explanation. On satisfactory explanation he/she shall be permitted to submit the report. Otherwise, it is deemed to have failed in the project work and shall register for the same in the subsequent semester.
- 4.4.6** Every candidate doing M.B.A based on his/her project has to publish the project work as full paper in International Conference or reputed Journal. An acknowledge for having communicate to the journal or conference shall be attached to the report of the project work.

4.5 Internship / Industrial Training

The students may undergo Industrial training during the summer / winter vacation. The student may undergo Industrial Training / Internship optionally and the credits earned will be indicated in the Grade Sheet as per details provided in Table 3. If the number of credits earned is 1 or 2 or 3, then these credits shall not be considered for computation of CGPA. However, it shall be recorded in the grade sheet.

Table 3: Internship

| Duration of Training/Internship | Credits |
|----------------------------------------|----------------|
| 2 Weeks* | 1 |
| 4 Weeks | 2 |
| 6 Weeks & above | 3 |

***1 Week = 40 Internship Hours**

- Students undergoing 6 weeks of training/doing projects in industry/academic institutions of repute shall be given 3 credits
- The evaluation shall be carried out based on the assessment by the industry/academic mentor (50%), report (25%) and viva-voce examination (25%).
- The viva-voce examination will be conducted internally by a three-member committee constituted by the HoD in consultation with the Head of the Institution.

4.5.1 Social Internship

The 100-hour experiential internship program would require the candidate to visit one or more villages and conduct activities of their choice to contribute to the cause of rural sanitation in India. The students undergoing Swachh Bharat Summer Internship and social internship shall earn 3 credits in lieu of professional /open electives.

4.6 Open Electives

Students shall be permitted to register for the open elective courses offered by other departments.

4.7 Value Added Courses

To promote students to gain Industrial exposure, the students shall undergo Value Added Courses (VAC) over and above the total credit's requirements prescribed in the curriculum for the award of the degree. The courses with two / three credits shall be offered with the approval of Academic Council. The credits earned through the Value-Added Courses shall not be included in the credit requirements prescribed in the curriculum for the award of the degree.

4.8 Mandatory/Audit courses

The student shall undergo mandatory/audit courses and it will be mentioned in the Grade Sheet. However, it will not be considered for computation of CGPA.

4.9 Off Campus Courses - NPTEL/SWAYAM/MOOC

Students are permitted to optionally enroll and study a maximum of five off campus courses in physical/online/hybrid mode under each PG programme with the approval of Academic council. The successful completion of these courses through physical/online/hybrid mode shall be considered in lieu of professional elective / open elective courses of curriculum as approved by the Head of the Institution.

4.9.1 Students can register for online courses only with the permission of the Head of the Department. Online courses shall be taken under the guidance of a faculty mentor. Credits shall be given to the students who have passed the online courses offered by NPTEL/SWAYAM. Suitable credits shall be given after due approval from the committee consisting of Head of the Department, programme coordinator, module coordinator / class advisor and course. The number of credits awarded to NPTEL Courses are based on the procedure given in Table 4 and the mapping of the NPTEL marks with the grades is explained in Annexure I. List of elective courses to be waived should be submitted to CoE at the beginning of the semester after the approval from the Head of the Institution.

Table 4: NPTEL Courses with Credits

| S.No. | No of Weeks | Number of Credits |
|-------|-------------|-------------------|
| 1 | 4 | 1 |
| 2 | 8 | 2 |
| 3 | 12 | 3 |
| 4 | 16 | 4 |

4.9.2 In addition, students are permitted to optionally enroll and study the courses in physical / hybrid / online modes offered by Central / State funded Universities / Institutions with 20 positions in NIRF Ranking, and also, conducting examination towards awards of marks and grades. Universities in abroad in top 500 in QS Ranking in the last three years. Students are also permitted to study courses of a semester in a University / Institution abroad based on MoU. A learning agreement shall be made based on the courses offered in the programme and the courses offered in the abroad university approved by Academic council. The credits earned by the students shall be transferred as per the learning agreement.

4.9.3 Students are also permitted to enroll and study the courses in physical / Online / Hybrid mode that are offered by (i) National / State funded research institutions / laboratories and (ii) reputed companies related to the programme. The minimum experience of the course instructor from the company shall be M.B.A with 10 years of research / industrial experience. The syllabus content, duration of the course and the number of credits shall be approved by Academic Council.

The course coordinator nominated from the department shall also attend the industry supported courses and coordinate in the Internal and End Semester Examination. However, the passing requirements are as per the regulations.

4.10 Self-study courses and International Certification Courses

Students shall be permitted to register for self-study course from IIIth semester onwards under a faculty mentor in a semester provided that they do not have any standing arrears and should have completed all the dropped courses. The students who opt for dropping of courses are not permitted to pursue self-study courses in that semester. Study materials prepared by the faculty mentor and delivered to students. No formal lectures need to be delivered.

However, the faculty mentor shall monitor the progress of the students on a weekly basis. Students shall write assignments/tutorials and appear for continuous assessment and end semester examinations to earn the credit. Students shall meet the faculty mentor once in a week. Students shall register for international certification courses offered by reputed national / International Organizations / Industries. The self-study courses shall be approved by the committee consisting of HoD, Programme Coordinator and Module Coordinators.

4.11 Ability Enhancement Courses

Ability Enhancement Courses will be offered in two categories as purely Laboratory Based Courses and Theory Integrated Laboratory Courses with the following credits.

Table 5: Ability Enhancement Courses

| Category | L | T | P | C |
|-------------------------------------|---|---|---|---|
| Laboratory Courses | 0 | 0 | 4 | 2 |
| | 0 | 0 | 2 | 1 |
| Theory Integrated Laboratory Course | 1 | 0 | 2 | 2 |

These courses may be offered with the support of the identified firms/companies and with one course coordinator per course and a mentor from the firm.

5 Medium of Instruction

The medium of instruction is English for all the course, for Examinations and Project Work reports.

6 DURATION OF THE PROGRAMME

6.1 The minimum and maximum period for the completion of the M.B.A Programmes is given in Table 6.

Table 6: Duration of the programmes

| Programme | Min. No. of Semesters | Max. No. of Semesters |
|-----------|-----------------------|-----------------------|
| M.B.A. | 4 | 8 |

6.2 Each semester shall normally consist of 90 working days (including examination days). The Head of the Department shall ensure that every teacher imparts instruction as per the number of periods specified in the syllabus, covering the full content of the syllabus for the course being taught.

6.3 The total duration for completion of the programme reckoned from the commencement of the first semester to which the student was admitted shall not exceed the maximum duration specified in clause 6.1 irrespective of the period of break of study (vide clause 20) or prevention (vide clause 8.) in order that the student may be eligible for the award of the degree (vide clause 18).

7. COURSE REGISTRATION

- 7.1** Each student, on admission, shall be assigned to a Class Advisor (vide clause 10), who shall advise and counsel the student about the details of the academic programme and the choice of courses, considering the student's academic background and career objectives.
- 7.2** After registering for a course, a student shall attend the classes, satisfy the attendance requirements, earn Continuous Assessment marks and appear for the End Semester Examinations.
- 7.2.1** Each student on admission shall register for all the courses prescribed in the curriculum in the student's first Semester of study.
- 7.2.2** The enrollment for all the courses from the Semesters II to final will commence 5 working days prior to the commencement of the succeeding semester. The student shall enroll for the courses with the guidance of the student's Faculty Advisor. If the student wishes, the student may drop or add courses (vide clause 7.3) within 10 working days after the commencement of the concerned semester and complete the registration process duly authorized by the Course Instructor within 30 days from the commencement of concerned semester. The list of students approved by the respective course instructor shall be final and would be considered for attendance, grades and calculation of CGPA and no changes shall be made thereafter.
- 7.2.3** Instead of two electives in the curriculum, the student may be permitted to choose a maximum of 2 courses from other PG programmes with the approval of the Head of the Department of student and Head of the Department offering such courses.
- 7.2.4** A student who has passed all the courses prescribed in the curriculum for the award of the degree shall not be permitted to re-enroll to improve the student's marks in a course or the aggregate marks / CGPA.
- 7.3 Flexibility to add or drop the courses**
- 7.3.1** A student must earn the total number of credits specified in the curriculum of the respective programme of study in order to be eligible to obtain the degree. From the II to Final semesters, the student has the option of registering for additional courses or dropping existing courses in a semester. The total number of credits that a student can add or drop in a semester is limited to 8, subject to a maximum of 2 courses. Maximum number of credits enrolled in a semester (including Shortage of Attendance (SA)) shall not exceed 33.

- 7.3.2** If the student wishes to earn more than the total number of credits prescribed in the curriculum of the student's programme within the minimum duration of the programme, then he/she can enroll for such additional courses in any programme with the permission of Head of the Department to which student belongs and Head of the Department in which the course is offered of by paying the examination fee. The credits earned will be neither considered for the computation of CGPA nor for the classification of the degree. The courses successfully completed will be printed in the grade sheet, however if there is shortage of attendance or failure, it shall neither be reflected in the grade sheet nor be considered for classification.

8 REQUIREMENTS OF ATTENDANCE AND PROGRESS

- 8.1** A student who has fulfilled the following conditions shall be deemed to have satisfied the requirements for completion of a semester.

Ideally every student is expected to attend all classes of all the courses and secure 100% attendance. However, in order to give provision for certain unavoidable reasons such as medical / participation in sports, the student is expected to attend at least 75% of the classes.

Therefore, he/she shall secure not less than 75% (after rounding off to the nearest integer) of overall attendance.

- 8.2** However, a student who secures overall attendance between 65% and 74% in the current semester due to medical reasons (prolonged hospitalization / accident / specific illness) / participation in sports events may be permitted to appear for the current semester examinations, subject to the condition that the student shall submit the medical certificate / sports participation certificate attested by the Head of the Institution. The same shall be forwarded to the Controller of Examinations for record purposes.
- 8.3** Students who secure less than 65% overall attendance shall not be permitted to write the University examination at the end of the semester and not permitted to move to the next semester. They are required to repeat the incomplete semester in the next academic year, as per the norms prescribed.

9 Readmission

Candidates who do not qualify to appear for end semester examinations of any semester for want of attendance and/or progress and/or character and conduct have to register for and repeat that semester at the next available opportunity subject to the approval of Directorate of Technical Education, Tamil Nadu and Anna University Chennai.

The re-admitted candidates have to follow the curriculum and syllabus as existing at the time of re-admission. The re-admission committee will decide the courses that he/she has to undergo in the new curriculum considering the

equivalent courses that he/she has gone through in the old curriculum, so as to bridge the curriculum in-force and the old curriculum. The courses recommended by the committee shall be taken under a faculty mentor and appear for the examination as specified by the college.

10. CLASS ADVISOR

To help students in planning their courses of study and for general advice on the academic programme, the Head of the Department will attach about 30 students to a faculty member of the Department who shall function as class advisor for those students.

Such class advisor shall advise the students and monitor the courses undergone by the students, check the attendance and progress of the students attached to him/her and counsel them periodically. If necessary, the class advisor may also discuss with or inform to the parents about the progress of the students through the Head of the Department concerned. Class advisor also helps the chairperson of the class committee in planning and conduct of the class committee meetings.

Class Advisor acts as the channel of communication between the HOD and the students of the respective class and also collects and maintain various statistical details of students.

The class advisor also helps the chairperson of the class committee in planning and conduct of the class committee meetings and also monitors the academic performance of the students including attendance and to inform the class committee, also makes the attend/involve in the students' welfare/development activities like awards, medals, scholarships and industrial visits.

11. CLASS COMMITTEE

11.1 Every class shall have a class committee consisting of student representatives, designated faculty members and a chairperson who is not teaching the class. It is like the 'Quality Circle' (more commonly used in industries) with the overall goal of improving the teaching-learning process. The functions of the class committee include,

- Solving problems experienced by students in the class room and in the laboratories.
- Clarifying the regulations of the degree programme and the details of rules there in particularly (clause 6 and 8).
- Informing the student representatives, the academic schedule including the dates of assessments and the syllabus coverage for each assessment.
- Informing the student representatives, the details of Regulations regarding weightage used for each assessment. In the case of practical courses (laboratory/ drawing/ project work / seminar etc.) the breakup of marks for each experiment/Mini projects / exercise / module of work,

should be clearly discussed in the class committee meeting and informed to the students.

- Analyzing the performance of the students of the class after each test and finding the ways and means to improve learning and performance.
- Identifying the weak students, if any, and requesting the teachers concerned to provide additional help or guidance or coaching to such weak students.

- 11.2** The class committee for a class under a particular branch is normally constituted by the Head of the Department. However, if the students of different branches are mixed in a class (like the first semester which is generally common to all branches), the class committee is to be constituted by the Head of the Institution.
- 11.3** The class committee shall be constituted in the first week of every semester.
- 11.4** At least 4 student representatives (usually 2 boys and 2 girls) shall be included in the class committee, covering all the elective courses.
- 11.5** The chairperson of the class committee may invite the faculty advisor(s) and the Head of the Department to the meeting of the class committee.
- 11.6** The Head of the Institution may participate in any class committee meeting of the Institution.
- 11.7** The chairperson is required to prepare the minutes of every meeting, submit the same to the Head of the Institution within two days of the meeting and arrange to circulate among the concerned students and faculties. If there are some points in the minutes requiring action by the management, the same shall be brought to the notice of the Management by the Head of the Institution.
- 11.8** The first meeting of the class committee shall be held within one week from the date of commencement of the semester, in order to inform the students about the nature and weightage of assessments within the framework of the Regulations. Two or three subsequent meetings may be held in a semester at suitable intervals. The class committee chairperson shall display the cumulative attendance particulars of each student of the Notice Board at the end of every such meeting to enable the students to know their attendance details to satisfy the Clause 8 of the Regulation. During these meetings the student members can express their opinions and suggestions of the other students of the class to improve the effectiveness of the teaching-learning process.

12. COURSE COMMITTEE FOR COMMON COURSES

Each common theory course offered to more than one section or more than one discipline or group, shall have a "Course Committee" comprising all the teachers teaching the common course with one of them nominated as course coordinator/ module coordinator. The nomination of the course coordinator shall be made by the Head of the Department / Head of the Institution depending upon whether all the teachers teaching the common course belong to a single department or to several departments. The 'Course Committee' shall meet regularly and ensure uniform evaluation of the tests and arrive at a common scheme of evaluation for the tests. Wherever it is feasible, the course committee may also prepare a common question paper for the internal assessment test(s).

13. SYSTEM OF EXAMINATION

13.1 Performance in each course of study shall be evaluated based on (i) continuous internal assessment throughout the semester and (ii) Semester Examination at the end of the semester.

13.2 Each course, both theory and practical (including project work & viva voce examinations) shall be evaluated for a maximum of 100 marks.

13.2.1 For all theory courses, the continuous internal assessment will carry **40 marks** while the End Semester examination will carry **60 marks**.

13.2.2 For all theory courses with laboratory component, the continuous internal assessment will carry **50 marks** while the End Semester examination with theory component will carry **50 marks**.

13.2.3 For all laboratory courses, the continuous internal assessment will carry **60 marks** while the End Semester examination will carry **40 marks**.

13.2.4 For all Project based courses, the continuous internal assessment will carry **50 marks** while the End Semester examination will carry **50 marks**.

13.2.5 The continuous internal assessment for the project work will carry **60 marks** while the End Semester examination will carry **40 marks**.

13.3 Industrial Training and Seminar shall carry 100 marks and shall be evaluated through internal assessment only.

13.4 The End Semester Examination (theory and practical) of 3 hours duration shall ordinarily be conducted between October and December during the odd semesters and between April and June during the even semesters.

13.5 The End Semester Examination for Project Work II shall consist of evaluation of the final report submitted by the student or students of the project group (of not exceeding 4 students) by an external examiner and an internal examiner, followed by a viva-voce examination conducted separately for each student by a committee consisting of the external examiner, the supervisor of the project

group and an internal examiner.

- 13.6** For the End Semester Examination of practical courses including Project Work, the examiners shall be appointed by the Controller of Examinations.

14 PROCEDURE FOR AWARDING MARKS FOR INTERNAL ASSESSMENT

For all theory, laboratory courses, theory cum practical component and project work-phase I, the continuous assessment shall be awarded as follows:

SCHEME OF ASSESSMENT

All M.C.A programmes consist of Theory Courses, Laboratory Courses, Theory with Laboratory Component Courses, Project Based Courses appearance in the End Semester Examination is mandatory. All other Career Guidance Courses Project Work-I, Seminar, Industrial/Practical Training, including Mandatory/Audit Courses are evaluated by continuous assessment only. Mandatory courses shall carry a maximum of 100 marks each and shall be evaluated through continuous assessment tests

14.1 THEORY COURSES

Two Continuous Assessment tests shall be conducted during the semester by the concerned department.

The total marks obtained in all assessments put together out of 200, shall be proportionately reduced for 40 marks and rounded to the nearest integer (This also implies equal weightage to the two assessments). The scheme of assessment is represented in the table 1.

If a candidate has not appeared in any of the two tests for valid reason after getting prior permission from the class advisor / Head of the Department / Head of the Institution, he/she is eligible to write missed tests. An improvement test is conducted for the students those who are interested in improving the internal marks in the respective course(s).

14.2 Theory courses with Laboratory Component

Weightage of internal assessment and end semester examination marks will be 50% each. The distribution of marks

for the theory and laboratory components in the internal assessments and end semester examination for different types of courses are provided in the table.

Table 7: Internal Assessments and End Semester Examination

| L | T | P | C | Internal Assessment 1 | Internal Assessment 2 | End Semester Examination |
|---|---|---|---|-----------------------|-----------------------|---------------------------|
| 1 | 0 | 4 | 3 | Lab (25%) | Theory (25%) | Lab only (50%) |
| 1 | 0 | 2 | 2 | Lab (25%) | Theory (25%) | Lab only (50%) |
| 2 | 0 | 2 | 3 | Theory (25%) | Lab (25%) | Theory (25%) Lab (25%) |
| 3 | 0 | 2 | 4 | Theory (25%) | Lab (25%) | Theory (35%) Lab (15%) |
| 2 | 0 | 4 | 4 | Theory (25%) | Lab (25%) | Theory (15%) Lab (35%) |

The procedure for the conduct of internal assessments for theory and laboratory components shall be as per the clause 14.1,14.2, 14.3 respectively.
*The weighted average shall be converted into 50 marks for internal Assessment.

Table 8: Scheme of Assessment

| Category of Courses | Continuous Assessment (Including Model Exam) | Assignment/ Tutorial/ Practical Examination and Contest | Two Quizzes | Internal | | End Sem |
|----------------------------------------------------------------------------------------|----------------------------------------------|---------------------------------------------------------|-------------|----------|----------|--------------|
| Theory | 25 marks | 10 marks | 5 marks | 40 marks | | 60 marks |
| Theory with Tutorial | 25 marks | 10 marks (Tutorial) | 5 marks | 40 marks | | 60 marks |
| Theory with Tutorial and Laboratory | 17.5 marks (Theory) | 5 marks (Tutorial) | 2.5 marks | 25 marks | 50 marks | 50 marks |
| | 15 marks (Lab Assessment) | 10 marks (Designathon/ Hackathon, etc) | - | 25 marks | | |
| Theory with Laboratory | 20 marks (Theory) | 2.5 marks | 2.5 marks | 25 marks | 50 marks | 50 marks |
| | 15 marks (Lab Assessment) | 10 marks (Designathon/ Hackathon, etc) | - | 25 marks | | |
| Project Based Courses | 20 marks | - | - | 50 marks | | 50 marks |
| | 30 marks (Project) | - | - | | | |
| Laboratory | - | 60 marks | - | 60 marks | | 40 marks |
| Procedure for Continuous Assessment of theory course | | | | | | |
| Item | | | | | | Marks |
| Periodical tests (2 Tests–2 hours each) (Each Test with 12.5 marks) | | | | 40 marks | | 60 marks |
| Procedure for Continuous Assessment of theory with laboratory courses | | | | | | |
| Periodical tests (2 Tests from theory portion -2 hours each, 2 Lab Exam -2 hours each) | | | | 50 Marks | | 50 Marks |

Table 9: Scheme of Assessment (Assignments/Tutorials)

| Assignments/Tutorials | | |
|-----------------------|----------------------------------------|------------------------------------------------------------------------------------------------------------------------------------------------------------------------------------------|
| Theory Courses | 3 Assignments | 3 x 50 Marks = 150Marks. This will be reduced to 10 Marks. Each assignment shall cover the requisite course outcomes, to check the understanding of the concepts and their applications. |
| Analytical Courses | No. of tutorials as per the time table | The average of marks obtained in all the tutorials shall be reduced to 5 marks. |

14.3 Laboratory Courses

The maximum marks for Internal Assessment shall be 60 marks in case of practical courses. Every practical exercise / experiment shall be evaluated based on conduct of experiment / exercise and records to be maintained. The criteria for arriving at the Internal Assessment marks of 60 is as follows: 75 marks shall be awarded for successful completion of all the prescribed experiments done in the Laboratory and 25 marks for the model test. The total mark shall be converted into a maximum of 60 marks and rounded to the nearest integer.

Table 10: Laboratory Assessment

| Internal Assessment (100 Marks) * | |
|------------------------------------------|-------------------------|
| Evaluation of Laboratory Record | Observation, Model Test |
| 75 | 25 |

* Internal assessment marks shall be converted into 60 marks

14.4 Project Work / Internship

14.4.1

The M.B.A students shall register for project work III Semester and IV Semester. There shall be three reviews conducted by the review committee. The student shall make presentation on the progress made by him / her before the committee. Students shall be permitted to take interdisciplinary and multidisciplinary projects. The total marks obtained in the three reviews shall be **reduced for 60 marks** and rounded to the nearest integer as per the scheme given below.

14.4.2

The project report shall be submitted as per the approved guidelines. The marks shall be awarded to every student for the project report. Marks are awarded to each student of the project is based on the performance in the viva- voce examination.

The student is also permitted to undergo a semester long internship in an industry / academic / research institution. Project Work shall be carried out under the supervision of a “qualified teacher” in the Department concerned. In this context “qualified teacher” means the faculty member possessing (i) PG degree or (ii) Ph.D. degree.

The Project Work carried out in industry / academic/research institution shall be jointly supervised. The Project Work shall be jointly supervised by a supervisor of the department and an expert from the organization as a joint supervisor and the student shall be instructed to meet the supervisor periodically and to attend the review committee meetings for evaluating the progress. The review meetings, if necessary, may also be arranged in online mode with prior approval from the Head of the Institution and suitable record of the meetings shall be maintained.

14.4.3

The Head of the Institution shall constitute a review committee for Project Work for each programme. The review committee consists of supervisor, an expert from the Department and a project coordinator from the Department. If the project coordinator/expert member happens to be the supervisor, then an alternate member shall be nominated. In the case of Industrial Project / Internship, the review committee shall consist of the supervisor, the coordinator from industry and the project coordinator from the Department.

There shall be three reviews conducted by the review committee. The student shall make presentation on the progress made by him / her before the

committee. The total marks obtained in the three reviews shall be reduced for 60 marks and rounded to the nearest integer (as per the scheme given in 12.4.4).

- 14.4.4** The project report shall carry a maximum of 10 marks. The project report shall be submitted as per the approved guidelines to controller of Examinations. The viva-voce examination shall carry 30 marks. Marks awarded to each student is based on the individual performance in the viva-voce examination.

Table 11: Project Work - II

| Continuous Assessment (60 Marks) | | | End Semester Examinations (40 Marks) | | | |
|-------------------------------------|-----------|------------|-----------------------------------------|-------------------------|-------------------|---------------------|
| Review I | Review II | Review III | Project Report | Viva – Voce Examination | | |
| 20 | 20 | 20 | External Examiner | Internal Examiner | External Examiner | Supervisor Examiner |
| | | | 10 | 10 | 10 | 10 |

In the case of industrial projects, the marks allotted for supervisor will be shared equally by the supervisor from the Department and coordinator from Industry.

- 14.4.5** The last date for submission of the project report is on the last working day of the semester. If a student fails to submit the project report on or before the specified deadline, it will be considered as fail in the Project Work and the student shall re-register for the same in the subsequent semester.
- 14.4.6** Students shall also undertake a start-up activity for the development of products as part of project work. If the outcome of a start-up is a fully developed product and whose concept is tested and validated, then it shall be considered in lieu of the project work. Such students shall submit a startup report, which includes the concepts and process flow of the developed product, publications, and patents, if any.

The evaluation of the start-up report is as per the clause 14.4.6

14.5.1 Other Career Guidance Courses

- a. The Seminar / Case Study / Mini Project course is to be considered as purely INTERNAL (with 100% internal marks only). Every student is expected to present a minimum of 2 seminars per semester before the evaluation committee and for each seminar, marks can be equally apportioned. The three-member committee appointed by the Head of the Institution, consisting of the course coordinator and two experts from the Department, will evaluate the seminar and at the end of the semester, the marks shall be consolidated and taken as one of the components in internal assessment.
- b. The Industrial/Practical Training, Summer Project, Internship, shall carry 100 marks and shall be evaluated through internal assessment only. At the end of Industrial / Practical Training / Internship / Summer Project,

the student shall submit an attendance certificate from the organization where he / she has undergone training with a brief report. The evaluation will be made based on this report and a viva-voce Examination, conducted internally by a three members Departmental Committee constituted by the Head of the Institution consisting of the course coordinator and two experts from the Department. The certificates (issued by the organization) submitted by the students shall be attached to the mark list sent by the Head of the Department to the Controller of Examinations.

- c. Courses under Career Guidance Courses Category, except the Project Work, the evaluation shall be done with 100% internal marks and as per the procedure described in clause 14 and one credit shall be offered as extra credit

14.6 ASSESSMENT FOR VALUE ADDED COURSES AND OTHER COURSES

14.6.1 Value Added Courses

The one / two credit course shall carry 100 marks and shall be evaluated through continuous assessments only. Two Assessments as per pattern given below and it shall be conducted by the Department concerned. The total marks obtained in the assessments shall be reduced to 100 marks and rounded to the nearest integer.

A committee consisting of the Head of the Department, staff handling the course and a senior faculty member nominated by the Head of the Institution shall do the evaluation process. The list of students along with the marks and the grades earned shall be forwarded to the Controller of Examinations for appropriate action at least one month before the commencement of End Semester Examinations. The grades earned by the students for Value Added Courses will be recorded in the Grade Sheet, however the same shall not be considered for the computation of CGPA.

Table 12: Value Added Courses/Certificate courses

| ITEMS | Marks |
|--------------|--------------|
| Test1 | 50 |
| Test II | 50 |
| Total Marks | 100 |

14.6.2 One credit Courses

Students shall be allowed to take courses offered by Industry experts for 15-20 hrs of duration and the same shall be considered as one credit courses. On successful completion and passing the examination in 3 one credit courses, a maximum of one 3 credit professional elective / open course may be waived in 7th semester. Suitable courses shall be offered after due approval of committee consisting of Head of the Department, programme coordinator, module coordinators and course coordinators in consultation with the Head of the Institution. The students are also permitted to study the one credit courses offered by other departments with the prior permission from the Head of the Institution.

**Table 13: One credit course
(Continuous Assessment only)**

| ITEMS | Marks |
|-----------------|-------|
| Test1 | 50 |
| Quiz/Assignment | 50 |
| Total Marks | 100 |

**Table 14: Industrial Training/ Internship
(Continuous Assessment Only)**

| ITEMS | Marks |
|------------------------|-------|
| Assessment by Industry | 30 |
| Viva-voce | 20 |
| Presentation | 30 |
| Case Study / Report | 20 |
| Total Marks | 100 |

Table 15: Soft Skills Training (CA only)

| ITEMS | Marks |
|----------------------------------------|-------|
| Written test | 50 |
| Oral Communication | 30 |
| Technical Paper Presentation\Interview | 20 |
| Total Marks | 100 |

14.7 System Based Examination and Open Book Examination

System Based Examination shall be conducted for programming related subjects for continuous assessment tests and the end semester examination. Computer aided examinations shall be conducted for analytical subjects on the lines of GATE examination for continuous assessment tests. Computer based Quiz shall be conducted for all courses.

Open book examination shall be conducted for continuous assessment tests for analytical courses as decided by BoS and approved by academic council and the committee consisting of HoD, Programme Coordinator and Module Coordinator.

14.8 Internal marks approved by the Head of the Institution shall be displayed by the respective HODs within 5 days from the last working day.

14.9 Attendance Record

Every teacher is required to maintain an 'ATTENDANCE AND ASSESSMENT RECORD', which consists of attendance marked in each lecture or practical or project work class, the test marks and the record of class work (topic covered), separately for each course. This should be submitted to the Head of the Department periodically (at least three times in a semester) for checking the syllabus coverage and the records of test marks and attendance. The Head of the Department will put his/her signature and date after due verification. At the

end of the semester, the record should be verified by the Head of the Institution who will keep this document in safe custody (for five years). The University or any inspection team appointed by the University may verify the records of attendance and assessment of both current and previous semesters.

14.10 Conduct of Academic Audit by every Institution

Every educational institution shall strive for a better performance of the students by conducting the internal assessments as mentioned in clause 14. In order to ensure the above, Academic Audit is to be done for every course taught during the semester. For the internal assessments conducted for each course as per details provided in clause 14, the academic records shall be maintained in the form of documentation for the individual assignments / case study report / report of mini project submitted by each student and assessment test question paper and answer script. Report of industrial training / internship shall also be maintained. For laboratory courses students' record shall be maintained. Further, the attendance of all students shall be maintained as a record.

The Head of the Institution shall arrange to conduct the Academic Audit for every course in a semester by forming the respective committees with an external course expert as one of the members drawn from a technical institution of repute near the institute.

The University or any inspection team appointed by the University may verify the records of Academic Audit report of the courses of both current and previous semesters, as and when required.

15. REQUIREMENTS FOR APPEARING FOR END SEMESTER EXAMINATIONS

A student shall normally be permitted to appear for the End Semester Examinations for all the courses registered in the current semester (vide clause 7) if he/she has satisfied the semester completion requirements (as per clause 8).

Further, examination registration by a student is mandatory for all the courses in the current semester and all arrear(s) course(s) for the End Semester Examinations failing which, the student will not be permitted to move to the higher semester.

A student who has already appeared for any course in a semester and passed the examination is not entitled to reappear in the same subject for improvement of grades.

16. PASSING REQUIREMENTS

16.1 A student who secures not less than 50% of total marks prescribed for the course [Internal Assessment + End semester Examinations] with a minimum of 45% of the marks prescribed for the End Semester Examination, shall be declared to have passed the course and acquired the relevant number of credits. This is applicable for both theory and laboratory courses (including project work).

- 16.2** If a student fails to secure a pass in a theory course, Integrated Course / laboratory course (except electives), the student shall register and appear only for the end semester examination in the subsequent semester. In such case, the internal assessment marks obtained by the student in the first appearance shall be retained and considered valid for all subsequent attempts till the student secures a pass. However, from the third attempt onwards if a student fails to obtain pass marks (IA + End Semester Examination) as per clause 16.1, then the student shall be declared to have passed the examination if he/she secures a minimum of 50% marks prescribed for the End semester examinations alone and will be awarded the lowest grade C.
- 16.3** If the course, in which the student has failed, is a Professional Elective or an Open Elective course, the student may be permitted to complete the same course. In such case, the internal assessment marks obtained by the student in the first appearance shall be retained and considered valid for all subsequent attempts till the student secures a pass. However, from the third attempt onwards if a student fails to obtain pass marks (IA + End Semester Examination) as per clause 16.1, then the student shall be declared to have passed the examination if he/she secures a minimum of 50% marks prescribed for the End Semester Examinations alone and will be awarded the lowest grade C.
- If any other Professional Elective or Open Elective course is opted by the student, the previous registration is cancelled and henceforth it is to be considered as a new Professional Elective or Open Elective course. The student has to register and attend the classes, earn the continuous assessment marks, fulfil the attendance requirements as per clause 8 and appear for the end semester examination.
- 16.4** If a student submitted the project report and absent during the viva - voce examination, it would be considered as fail. In case, the student fails in the subsequent viva -voce examination also, the student shall register for the course again in the subsequent semester and can-do Project Work-I and Project Work-II together.
- 16.5** The passing requirement for the courses which are assessed only through purely internal assessments (CG courses except Project Work and laboratory), is 50% of the internal assessment (continuous assessment) marks only.
- 16.6** A student can apply for revaluation of the student's semester examination answer paper in a theory course, as per the guidelines of the CoE on payment of a prescribed fee along with prescribed application to the CoE through the Head of the Institution. The CoE will arrange for the revaluation and the results will be intimated to the student concerned through the Head of the Institution. Revaluation is not permitted for laboratory course and CG courses.

17 AWARD OF LETTER GRADES

17.1 The award of letter grades will be decided using relative grading principle except Laboratory Courses and Project Work. The performance of a student will be reported using letter grades, each carrying certain points as detailed below:

Table 16: Letter Grades

| Letter Grade | Grade Points* |
|-----------------------------|----------------------|
| O (Out Standing) | 10 |
| A+ (Excellent) | 9 |
| A (Very Good) | 8 |
| B+ (Good) | 7 |
| B (Average) | 6 |
| C (Satisfactory) | 5 |
| U (Re-Appearence) | 0 |
| SA (Shortage of Attendance) | 0 |
| WD (Withdrawal) | 0 |

A student is deemed to have passed and acquired the corresponding credits in a particular course if he/she obtains any one of the following grades: "O", "A+", "A", "B+", "B", "C".

'SA' denotes shortage of attendance (as per clause 8.3) and hence prevented from writing the end semester examinations. 'SA' will appear only in the result sheet.

"U" denotes that the student has failed to pass in that course. "WD" denotes withdrawal from the exam for the particular course. The grades U and WD will figure both in the Grade Sheet as well as in the Result Sheet. In both cases, the student has to appear for the End Semester Examinations as per the Regulations.

If the grade U is given to Theory Courses/ Laboratory Courses it is not required to satisfy the attendance requirements (vide clause 8), but has to appear for the end semester examination and fulfil the norms specified in clause 16 to earn a pass in the respective courses.

If the grade U is given to CG course (except Project Work), which are evaluated only through internal assessment, the student shall register for the course again in the subsequent semester, fulfil the norms as specified in clause 14 to earn pass in the course. However, attendance requirement need not be satisfied.

17.1.1 Relative Grading

For those students who have passed the course (theory course, theory cum practical courses except laboratory course / Project Work Courses), the relative grading shall be done. The marks of those students who have passed only shall be given as input in the software developed for relative

grading. The evolved relative grading method normalizes the results data using the BOX-COX transformation method and computes the grade range for each course separately and awards the grade to each student. (Theory course / laboratory integrated courses / theory integrated courses and all other EEC Courses). If the students' strength is greater than 30, the relative grading method shall be adopted.

17.1.2 Absolute Grading

- In all the courses, if the number of students who have passed the course is less than or equal to 30 then absolute grading shall be followed with the grade range as specified in the Table.
- For the Project Work / Internship and Laboratory Courses, absolute grading procedure shall be followed as given in the Table below irrespective of the number of students who have passed the course.

Table 17: Grade range for absolute grading

| O | A+ | A | B+ | B | C | U |
|----------|---------|---------|---------|---------|---------|-----|
| 91 - 100 | 81 - 90 | 71 - 80 | 61 - 70 | 56 - 60 | 50 - 55 | <50 |

Successful completion of any one of the above co-curricular activities is compulsory for the award of degree.

17.2 The grades O, A+, A, B+, B, C obtained for the one / two credit course (not the part of curriculum) shall figure in the Grade Sheet under the title 'Value Added Courses/Internship/Industrial training'. The courses for which the grades obtained are RA, SA will not figure in the Grade Sheet.

17.3 For the students admitted under non-computer science background category, the grades obtained for the prescribed bridge courses will appear on the grade sheet, but it will not be considered for CGPA calculation.

17.4 For the students who complete the Mandatory Course satisfying attendance requirement, the title of the Mandatory Course will be mentioned in the Grade Sheet.

17.5 GRADE SHEET

After results are declared, Grade Sheets will be issued to each student which will contain the following details:

- The college in which the student has studied
- List of courses studied for Hons., Minor and any other additional courses in which the student has passed with the grades under the title additional courses.
- The Grade Point Average (GPA) for the semester considering only the courses of curriculum (not the additional courses) and
- The Cumulative Grade Point Average (CGPA) of all courses registered from first semester onwards considering only the courses of curriculum (not the additional courses).
- During each semester, the list of curricular courses (not the additional

courses) registered and the grades scored in each course are used to compute the Grade Point Average (GPA). GPA is the ratio of the sum of the products of the number of credits of curricular courses (not the additional courses) registered and the grade points corresponding to the grades scored in those courses, taken for all the courses, to the sum of the number of credits of all the courses in the semester. U grades will be excluded for calculating GPA and CGPA.

$$\text{GPA / CGPA} = \frac{\sum_{i=1}^n C_i GP_i}{\sum_{i=1}^n C_i}$$

Where **C_i** is the number of Credits assigned to the course

GP_i is the point corresponding to the grade obtained for each Course

n is number of all courses successfully cleared during the particular semester in the case of GPA and during all the semesters in the case of CGPA.

If a student study more number of professional and open electives than required as per the student's programme curriculum, the calculation of final CGPA shall be as per 4.14.6 and 4.14.7.

17.5.1

In the consolidated grade sheet, the CGPA earned shall be converted into percentage of marks as follows:

Percentage of Marks = CGPA × 10.

18 ELIGIBILITY FOR THE AWARD OF THE DEGREE

18.1 A student shall be declared to be eligible for the award of the M.B.A Degree provided the student has

- i. Successfully gained the required number of total credits as specified in the curriculum corresponding to the student's programme within the stipulated time.
- ii. Successfully completed the course requirements, appeared for the End Semester examinations and passed all the subjects within the period as prescribed in clause 6.
- iii. Successfully passed any additional courses whenever the student is readmitted with earlier Regulations.
- iv. No disciplinary action pending against the student.
- v. The award of Degree must have been approved by the Syndicate of the University.

18.2 CLASSIFICATION OF THE DEGREE AWARDED

18.2.1 FIRST CLASS WITH DISTINCTION

A Student who satisfies the following conditions shall be declared to have passed the examination in **First class with Distinction**:

- Should have passed the examination in all the courses of all the four semesters in the student's First Appearance within **three** years, which includes authorised break of study of one year (if availed). Withdrawal

from examination (vide clause 19) will not be considered as an appearance.

- Should have secured a CGPA of not less than **8.50**.
- Should NOT have been prevented from writing end Semester examination due to lack of attendance in any of the courses

18.2.2 FIRST CLASS

A student who satisfies the following conditions shall be declared to have passed the examination in First class:

- Should have passed the examination in all the courses of all four semesters within three years, which includes one year of authorized break of study (if availed) or prevention from writing the End Semester Examination due to lack of attendance (if applicable).
- Should have secured a CGPA of not less than 6.50.

18.2.3 SECOND CLASS

All other students (not covered in clauses 18.2.1 and 18.2.2) who qualify for the award of the degree (vide clause 16.1) shall be declared to have passed the examination in Second Class.

18.4 Photocopy / Revaluation

A student can apply for photocopy of his/her semester examination answer paper in a theory course, as per the guidelines of the CoE, on payment of a prescribed fee through proper application to the Controller of Examinations through the Head of the Department. The answer script is to be valued and justified by a faculty member, who has handled the subject and recommend for revaluation with the breakup of marks for each question.

Based on the recommendation, the student can register for the revaluation through proper application to the Controller of Examinations. The Controller of Examinations will arrange for the revaluation and the results will be intimated to the student concerned through the Head of the Institutions. Revaluation is not permitted for practical courses and CG courses.

18.5 Review

Students not satisfied with Revaluation can apply for Review of his/ her examination answer paper in a theory course, within the prescribed date on payment of a prescribed fee through proper application to the Controller of Examinations through the Head of the Department. Students applying for Revaluation only are eligible to apply for Review. Students shall forward the grievances related to assessment, examination and other curricular related issues to grievance redressal committee.

19 PROVISION FOR WITHDRAWAL FROM END-SEMESTER EXAMINATION

19.1 A student may, for valid reasons, (medically unfit / unexpected family situations / sports approved by the Chairman, Sports Board and the HOD) be granted permission to withdraw from appearing for the end semester examination in any course or courses in **ANY ONE** of the semester examinations during the entire duration of the degree programme. The application shall be sent to the COE through the Head of the Institution with

required documents.

- 19.2** Withdrawal application is valid if the student is otherwise eligible to write the examination (clause 8) and if it is made within TEN days after the date of the examination(s) in that course or courses and recommended by the Head of the Institution and approved by the Controller of Examinations. For a student to withdraw from a course / course, he/she should have registered for the course, fulfilled the attendance requirements (vide clause 8) and earned continuous assessment marks.
- 19.2.1** Notwithstanding the requirement of mandatory 10 days, applications for withdrawal for special cases under extraordinary conditions will be considered on the merit of the case.
- 19.3** In case of withdrawal from a course / course, the courses will figure both in the Grade Sheet as well as in the Result Sheet. However, withdrawal shall not be considered as an appearance for the eligibility of a student for First Class with Distinction.
- 19.4** If a student withdraws from writing end semester examinations for a course or courses, he/she shall register for the same in the subsequent semester and write the end semester examination(s).
- 19.5** If a student applies for withdrawal from Project Work, he/she will be permitted for the withdrawal only after the submission of project report before the deadline. However, the student may appear for the viva-voce examination within 60 days after the declaration of results for Project Work I and II respectively and the same shall not be considered as reappearance.

- 19.6** Withdrawal is permitted for the end semester examinations in the final semester, as per clause 19

20 PROVISION FOR AUTHORISED BREAK OF STUDY

- 20.1** A student is permitted to go on authorized break of study for a maximum period of one year as a single spell.
- 20.2** Break of Study shall be granted only once for valid reasons for a maximum of one year during the entire period of study of the degree programme. However, in extraordinary situation the student may apply for additional break of study not exceeding another one year. If a student intends to temporarily discontinue the programme in the middle of the semester for valid reasons, and to re-join the programme in a subsequent year, permission may be granted based on the merits of the case provided he / she applies to the Director, Student Affairs in advance, but not later than the last date for registering for the end semester examination of the semester in question, through the Head of the Institution stating the reasons therefore and the probable date of re-joining the programme.
- 20.3** The student permitted to rejoin the programme after break of study / prevention due to lack of attendance, shall be governed by the Curriculum

and Regulations in force at the time of rejoining. The students rejoining in new Regulations shall register for additional courses, if any, under change of Regulations. These courses may be from any of the semesters of the curriculum in force, so as to bridge the curriculum in force and the old curriculum.

- 20.3.1** Total number of credits to be earned by the student shall be more than or equal to the total number of credits prescribed in the curriculum in force. If the credit assigned for L T P of the courses are not same in two Regulations under consideration, then equivalence shall be arrived as per the credit assignment followed in the Regulations in force.
- 20.4** The authorized break of study is included in the duration specified for passing all the courses for the purpose of classification (vide clause 20).
- 20.5** The total period for completion of the Programme reckoned from, the commencement of the first semester to which the student was admitted shall not exceed the maximum period specified in clause 6 irrespective of the period of break of study in order that he/she may be eligible for the award of the degree.
- 20.6** If any student is prevented for want of required attendance, the period of prevention shall not be considered as authorized 'Break of Study' (clause 20).
- 20.7** If a student in Full Time mode wants to take up a job / start-up / entrepreneurship during the period of study, he/she shall apply for authorized break of study for one year. The student shall join the job / start-up / entrepreneurship only after getting approval of the same by the Director, Centre for Academic Courses with due proof to that effect.
- 20.8** No fee is applicable to students during the Break of Study period.

21 DISCIPLINE

- 21.1** Every student is required to observe disciplined and decorous behaviour both inside and outside the college and not to indulge in any activity which will tend to bring down the prestige of the University / College. The Head of the Institution shall constitute a disciplinary committee consisting of the Head of the Institution, Two Heads of Department of which one should be from the faculty of the student, to enquire into acts of indiscipline and notify the University about the disciplinary action recommended for approval. In case of any serious disciplinary action which leads to suspension or dismissal, then a committee shall be constituted including one representative from Anna University, Chennai. In this regard, the member will be nominated by the University on getting information from the Head of the Institution.
- 21.2** If a student indulges in Malpractice in any of the End Semester Examination / internal examination he / she shall be liable for punitive action as prescribed

by the University from time to time.

22. REVISION OF REGULATIONS, CURRICULUM AND SYLLABI

The College may from time-to-time revise, amend or change the Regulations, scheme of examinations and syllabi if found necessary, through the approval of respective BoS and Academic Council of the College.



Mapping of NPTEL Marks with Grades

I. The following procedure is followed to map the NPTEL marks with grades, if number of students passed in NPTEL examination is greater than 1.

1. The marks scored by each student in a course is registered (x_i)
2. The Total Number of students passed in the course (N)
3. Average / Mean is calculated

$$\text{Mean } (\mu) = \frac{\text{Total marks of all students}}{\text{No. of students (N)}}$$

4. The standard Deviation (σ) =
$$\sqrt{\frac{\sum_{i=1}^N (x_i - \mu)^2}{N - 1}}$$

5. The grading intervals are calculated using the formula

$$x_i = \mu + i \frac{\sigma}{2}$$

$$y_i = \mu - i \frac{\sigma}{2}$$

Where $i = 1, 3, 5, \dots$

6. Based on the marks scored and the value of x_i , the ranges of marks for a particular grade is fixed.

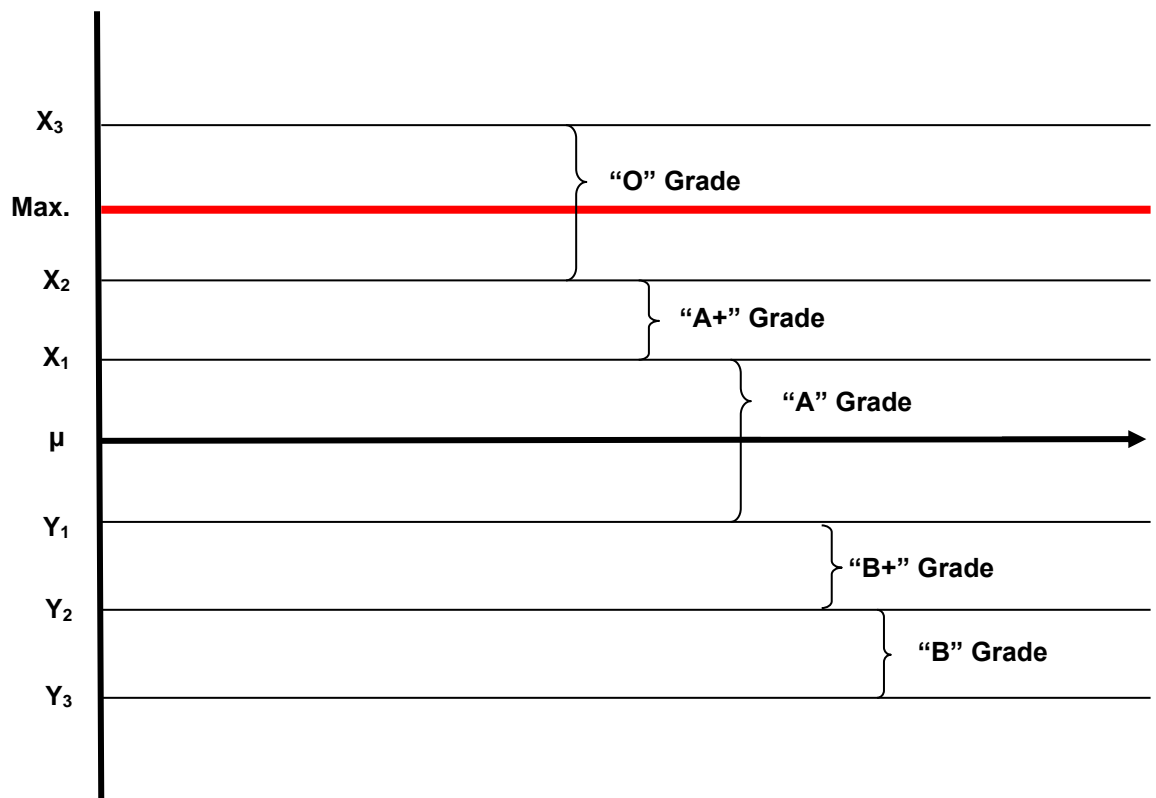

Sample Calculation:**Subject Name:** Education for Sustainable Development

| S. No. | Reg. No. | Name | NPTEL Mark | Mark - Mean | (Mark - Mean) ² | Grade |
|--------|------------------|---------------------|------------|-------------|----------------------------|-------|
| 1 | 2303737710421014 | GURU PRASATH L | 55 | -10 | 100 | B+ |
| 2 | 2303737710421017 | HARIPRASANTH B B | 80 | 15 | 225 | O |
| 3 | 2303737710421034 | NATARAJAN S | 75 | 10 | 100 | A+ |
| 4 | 2303737710422071 | ABI MALAR R A | 54 | -11 | 121 | B+ |
| 5 | 2303737710422079 | DHARANIPRIYA M | 75 | 10 | 100 | A+ |
| 6 | 2303737710422082 | GOPIKA SELVENTHIRAN | 66 | 1 | 1 | A |
| 7 | 2303737710422113 | SHARMI R V | 55 | -10 | 100 | B+ |
| 8 | 2303737710422119 | SWEATHA S | 71 | 6 | 36 | A+ |
| 9 | 2303737714821004 | ALLWIN JEROME J | 61 | -4 | 16 | A |
| 10 | 2303737714821005 | ARJUN SELVAKUMAR | 67 | 2 | 4 | A |
| 11 | 2303737714821021 | LOKESH VERMA P | 72 | 7 | 49 | A+ |
| 12 | 2303737714821022 | MEGANATHAN | 60 | -5 | 25 | A |
| 13 | 2303737714821038 | THARUNKUMAR R | 54 | -11 | 121 | B+ |
| 14 | 2303737714821039 | VIJAY E | 53 | -12 | 144 | B+ |
| 15 | 2303737714822058 | SUBHAHARINI R | 75 | 10 | 100 | A+ |

| | | | |
|-------------------------------|------------|----------------------------------|-------------|
| Total marks of all students = | 973 | $\Sigma (x_i - \mu)^2 =$ | 1242 |
| $\mu = (973 / 15)$ | 65 | $\Sigma (x_i - \mu)^2 / (N - 1)$ | 88.71 |
| | | $\sigma =$ | 9.42 |

| | | | |
|-----------------------|-------|-----------------------|-------|
| $\mu + (\sigma / 2)$ | 69.58 | $\mu - (\sigma / 2)$ | 60.16 |
| $\mu + (3\sigma / 2)$ | 78.99 | $\mu - (3\sigma / 2)$ | 50.73 |
| $\mu + (5\sigma / 2)$ | 88.41 | $\mu - (5\sigma / 2)$ | 41.32 |

| Grade | O | A+ | A | B+ | B | C |
|------------|-----|---------|---------|---------|---------|----|
| NPTEL Mark | >78 | 69 - 77 | 60 - 68 | 50 - 59 | 41 - 49 | 40 |

II. The following procedure is followed to map the NPTEL marks with grades, if number of students passed in NPTEL examination is equal to 1.

| Letter Grade | NPTEL Marks |
|--------------|-------------|
| O | 90 – 100 |
| A+ | 80 – 89 |
| A | 70 – 79 |
| B+ | 60 – 69 |
| B | 50 – 59 |
| C | 40 – 49 |



K.S.RANGASAMY COLLEGE OF TECHNOLOGY, TIRUCHENGODE- 637 215

(An Autonomous Institution, Affiliated to Anna University, Chennai)

1. Student Intern Performance Review / Employer Assessment of Intern Form

We appreciate your contribution to the professional growth and development of our students. In order for us to best assess the experience, we request you to complete this form and return it to us at the end of the internship period. We believe that your comments will help the student to build his career.

2. Student Information

| | | | |
|----------------------|-------|-------------------|--|
| Intern's Name | | Department | |
| Semester | | Type: Paid/Unpaid | |
| Period of Internship | From: | To: | |

Please rate the intern in each area using the following criteria and score:

Not Applicable-0; Not acceptable-1; Needs improvement-2; Meets Requirements-3; Above Average-4 ; Exceptional-5.

1. Adherence to Work Schedule

Meets attendance and punctuality expectations; completes assigned tasks in time; keeps commitments and takes responsibility for own actions.

| | | |
|---------------------------------------------|--------------------------------------------|-----------------------------------------|
| <input type="checkbox"/> Meets Requirements | <input type="checkbox"/> Needs improvement | <input type="checkbox"/> Above Average |
| <input type="checkbox"/> Exceptional | <input type="checkbox"/> Not Applicable | <input type="checkbox"/> Not acceptable |

2. Team Player

Consistently demonstrates proactive nature takes independent action and calculated risks; knows when to seek prior approval.

| | | |
|---------------------------------------------|--------------------------------------------|-----------------------------------------|
| <input type="checkbox"/> Meets Requirements | <input type="checkbox"/> Needs improvement | <input type="checkbox"/> Above Average |
| <input type="checkbox"/> Exceptional | <input type="checkbox"/> Not Applicable | <input type="checkbox"/> Not acceptable |

3. Communication Skills

Exhibits good listening and comprehension; Interacts well with others and resolves conflicts.

| | | |
|---------------------------------------------|--------------------------------------------|-----------------------------------------|
| <input type="checkbox"/> Meets Requirements | <input type="checkbox"/> Needs improvement | <input type="checkbox"/> Above Average |
| <input type="checkbox"/> Exceptional | <input type="checkbox"/> Not Applicable | <input type="checkbox"/> Not acceptable |

4. Learning Curve

Competent in required job skills and knowledge; exhibits ability to learn and apply new skills; requires minimal supervision ability to apply creative solutions to problems.

| | | |
|---------------------------------------------|--------------------------------------------|-----------------------------------------|
| <input type="checkbox"/> Meets Requirements | <input type="checkbox"/> Needs improvement | <input type="checkbox"/> Above Average |
| <input type="checkbox"/> Exceptional | <input type="checkbox"/> Not Applicable | <input type="checkbox"/> Not acceptable |

5. Decision Making

Accepts criticism and constructive feedback applies skills appropriate for carrying tasks and solving problems; makes sound decisions.

- | | | |
|---------------------------------------------|--------------------------------------------|-----------------------------------------|
| <input type="checkbox"/> Meets Requirements | <input type="checkbox"/> Needs improvement | <input type="checkbox"/> Above Average |
| <input type="checkbox"/> Exceptional | <input type="checkbox"/> Not Applicable | <input type="checkbox"/> Not acceptable |

6. Responsibility and Reliability

Demonstrates accuracy and thoroughness; work reflects compliance to standards, commitment excellence and attention to detail; strives to increase productivity.

- | | | |
|---------------------------------------------|--------------------------------------------|-----------------------------------------|
| <input type="checkbox"/> Meets Requirements | <input type="checkbox"/> Needs improvement | <input type="checkbox"/> Above Average |
| <input type="checkbox"/> Exceptional | <input type="checkbox"/> Not Applicable | <input type="checkbox"/> Not acceptable |

7. Employment Skills

Willingness to learn new skills which are job-specific or more general.

- | | | |
|---------------------------------------------|--------------------------------------------|-----------------------------------------|
| <input type="checkbox"/> Meets Requirements | <input type="checkbox"/> Needs improvement | <input type="checkbox"/> Above Average |
| <input type="checkbox"/> Exceptional | <input type="checkbox"/> Not Applicable | <input type="checkbox"/> Not acceptable |

8. Technical Competencies

Ability to apply learned skills to the internship work environment

- | | | |
|---------------------------------------------|--------------------------------------------|-----------------------------------------|
| <input type="checkbox"/> Meets Requirements | <input type="checkbox"/> Needs improvement | <input type="checkbox"/> Above Average |
| <input type="checkbox"/> Exceptional | <input type="checkbox"/> Not Applicable | <input type="checkbox"/> Not acceptable |

9. Critical Thinking and Problem Solving Skills

Demonstrates critical thinking and problem solving skills

- | | | |
|---------------------------------------------|--------------------------------------------|-----------------------------------------|
| <input type="checkbox"/> Meets Requirements | <input type="checkbox"/> Needs improvement | <input type="checkbox"/> Above Average |
| <input type="checkbox"/> Exceptional | <input type="checkbox"/> Not Applicable | <input type="checkbox"/> Not acceptable |

10. Ethics & Professionalism

Understand the ethical responsibility towards society and the principles of fairness while dealing with all stakeholders.

- | | | |
|---------------------------------------------|--------------------------------------------|-----------------------------------------|
| <input type="checkbox"/> Meets Requirements | <input type="checkbox"/> Needs improvement | <input type="checkbox"/> Above Average |
| <input type="checkbox"/> Exceptional | <input type="checkbox"/> Not Applicable | <input type="checkbox"/> Not acceptable |

OVERALL EVALUATION:

Total Marks:

| |
|-----------|
| |
| 50 |

Please give in written form of assessment of the student's performance.

Is the student better prepared for the industry? What is the possibility of being hired as a permanent employee in your concern?

What is your suggestion for improvement of the intern?

Employer Information:

| | |
|------------------------------------|--|
| Name and Signature of the Reviewer | |
| Designation & email | |
| Name of the Company | |
| Address | |
| Date of Evaluation | |